

This is the “summary” of the items and relations that we need to path between SPEL and SPI back and forth.

Below you will see more of the data model of SPEL with specific information.

Wiring equipment is here to represent the fact that ControlStation can also have IOTagSignal.

Instrument is an Equipment in this model

- PlantItemJoin represent the relation between PlantItem to the other. This is what build the Tree that represent the Electrical load relation.

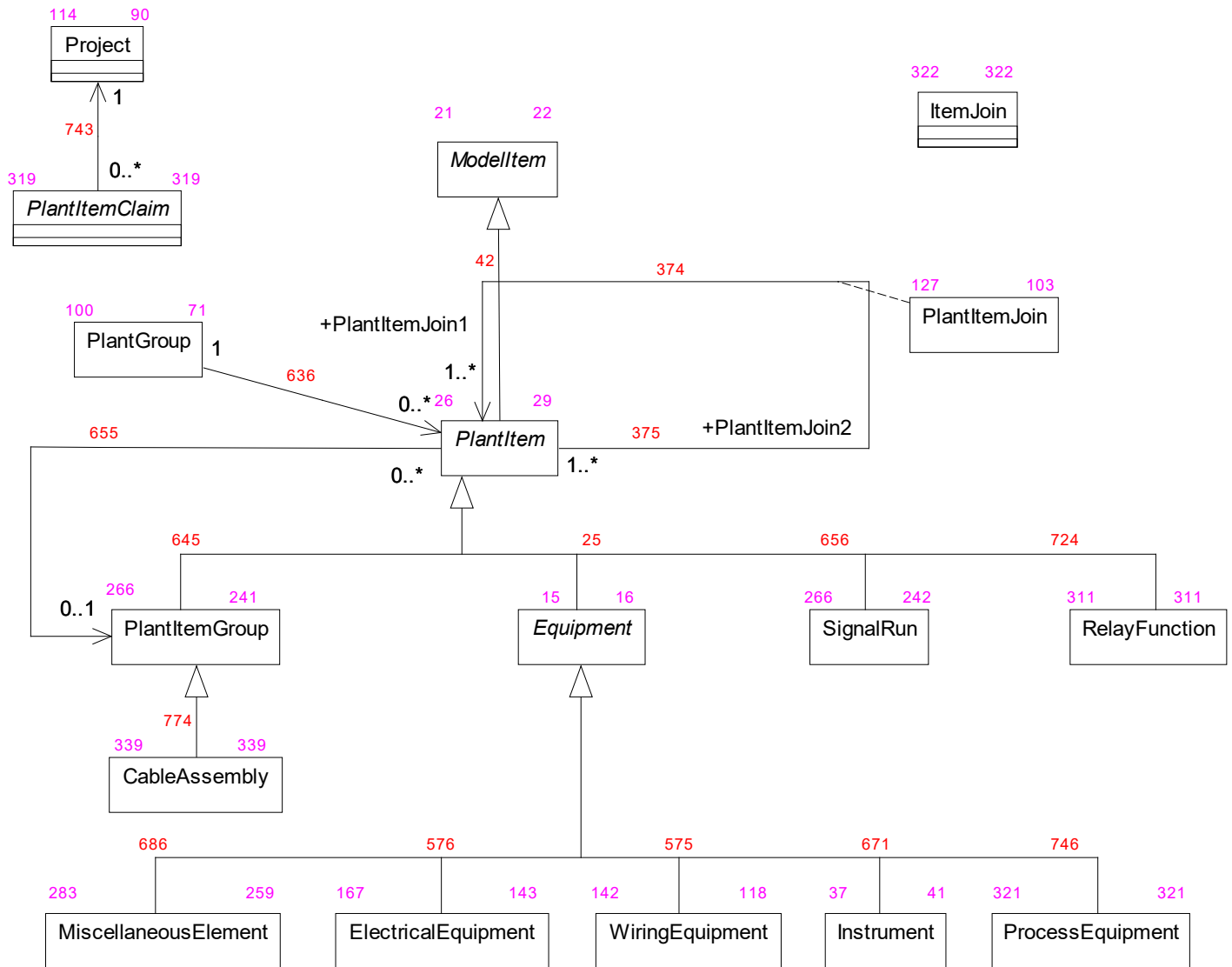

This is the hierarchy of electrical equipment

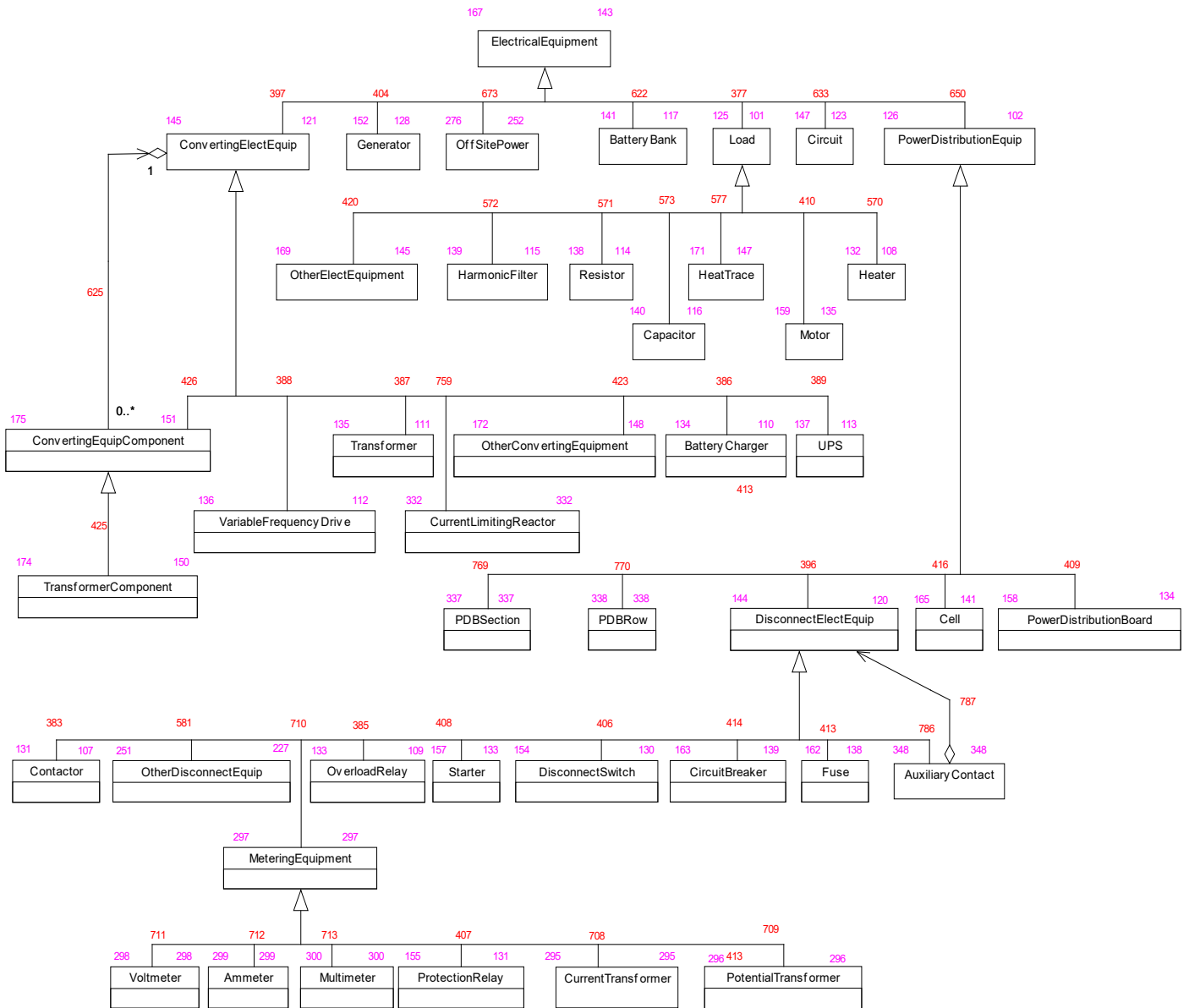

This is the hierarchy of wiring equipment

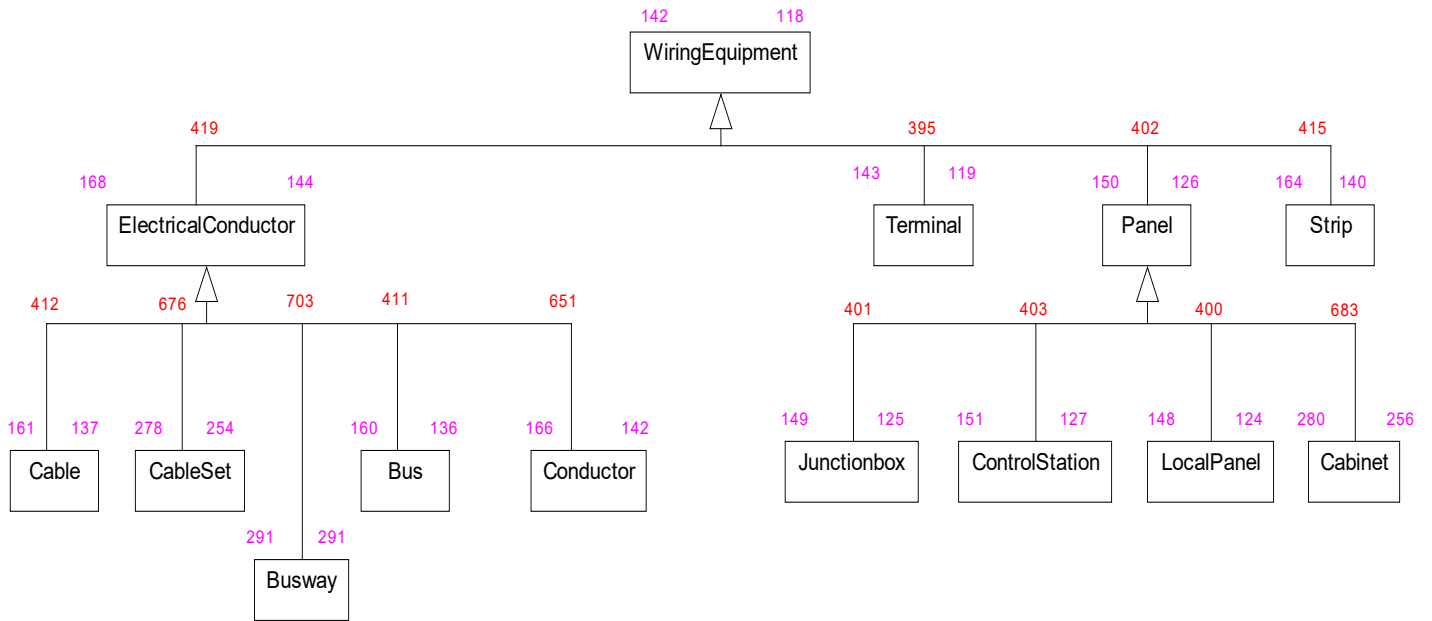

Some of the Relations between Plant and Reference items

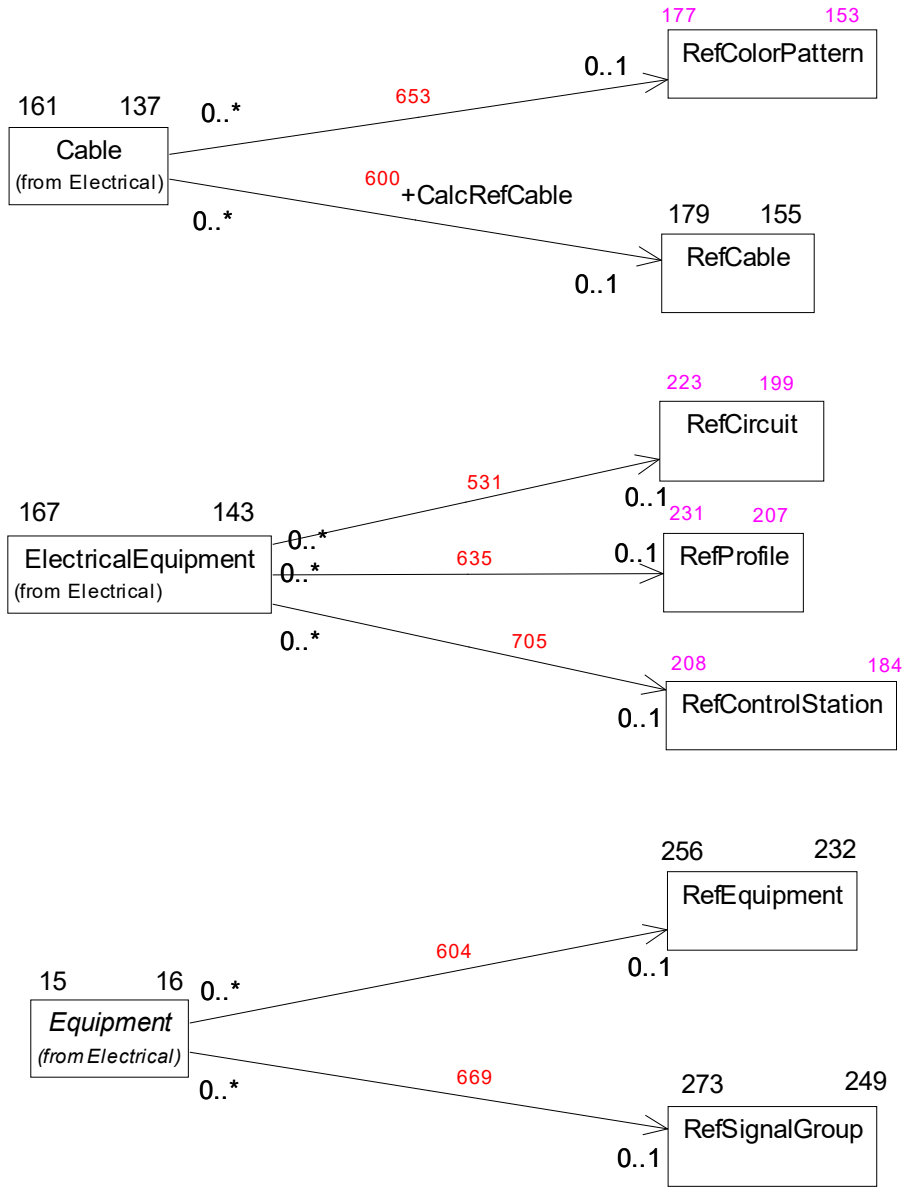

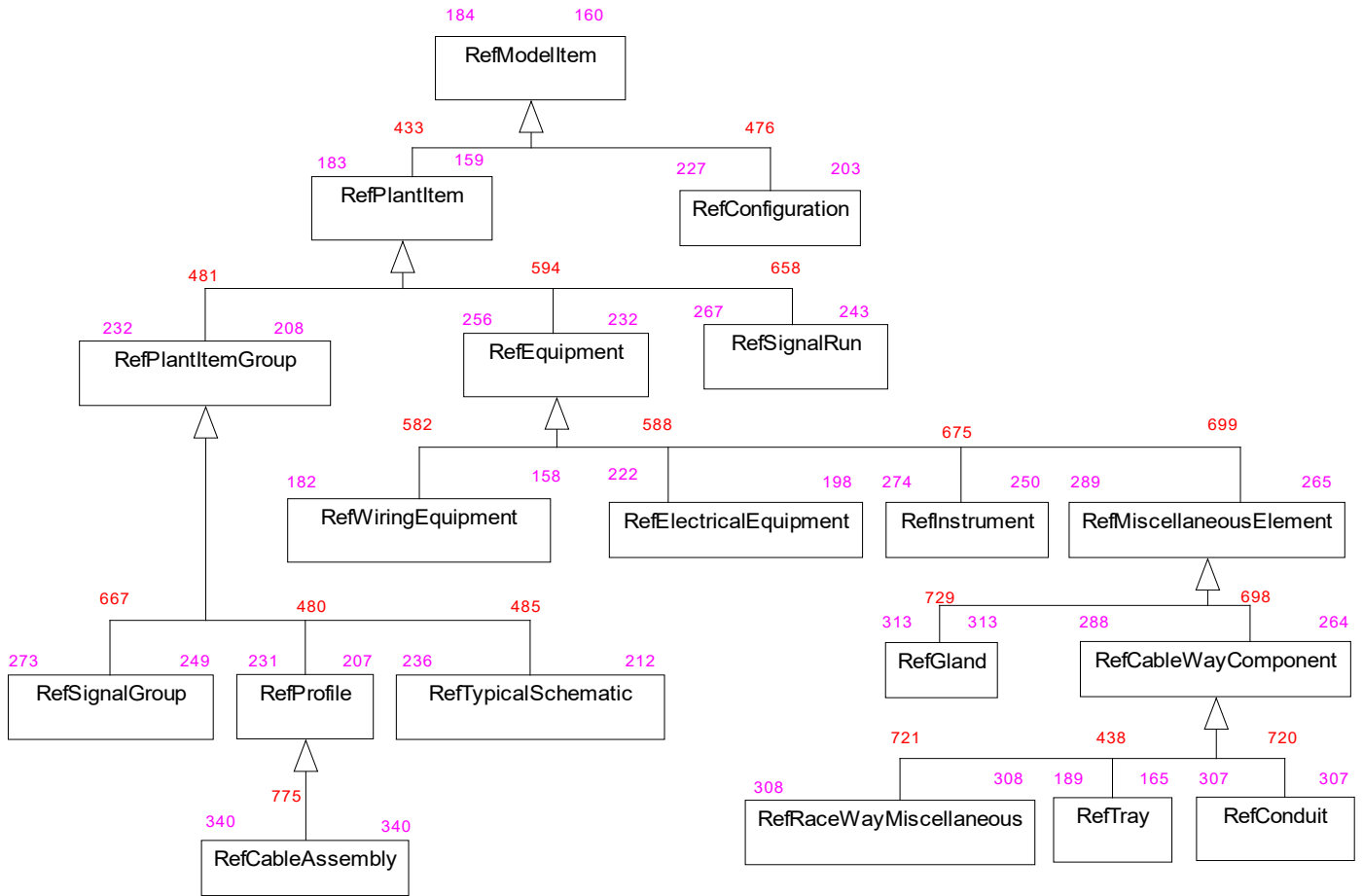

Reference electrical equipment

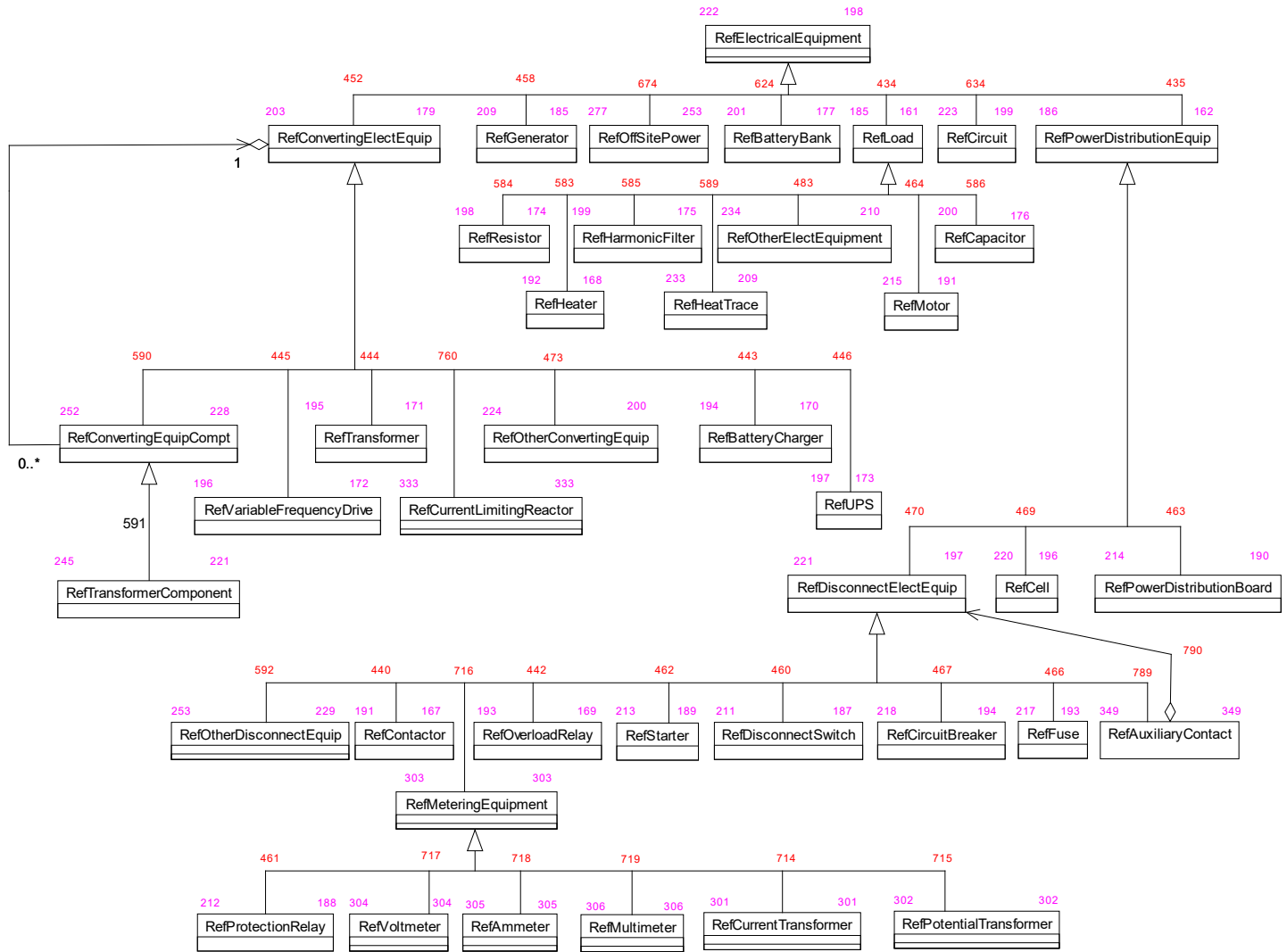

Reference wiring equipment

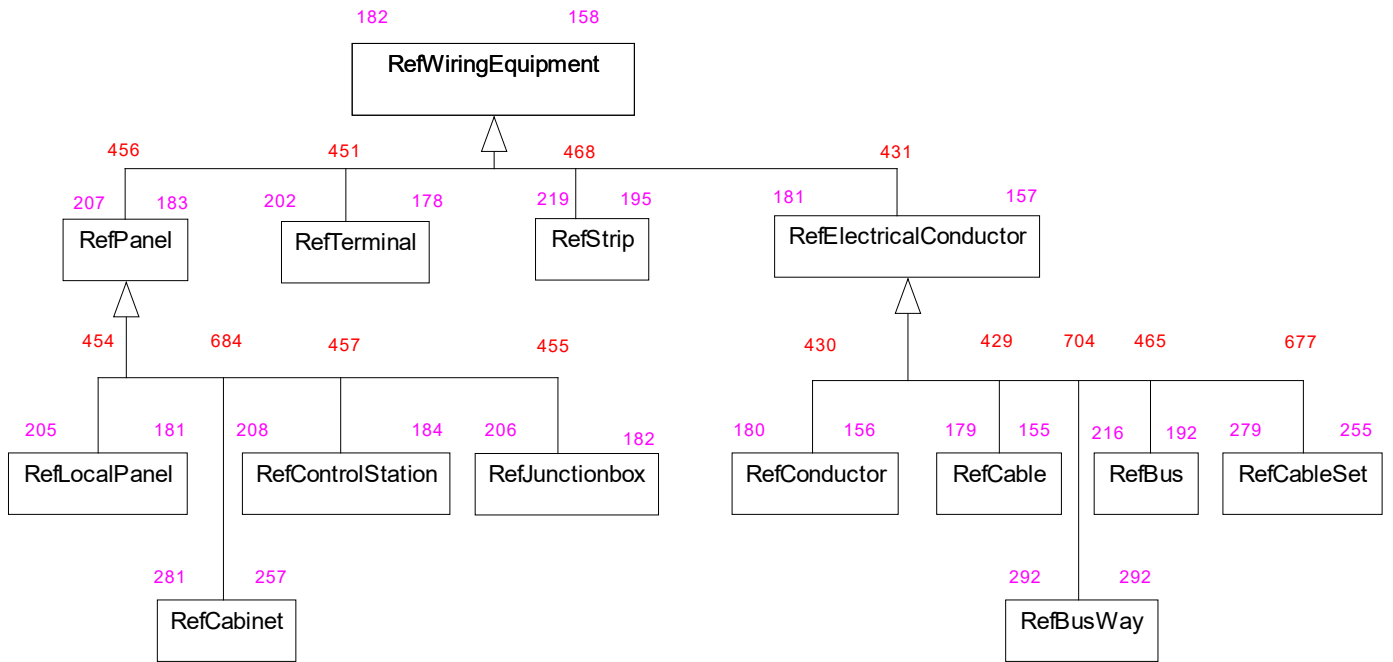

Document related items

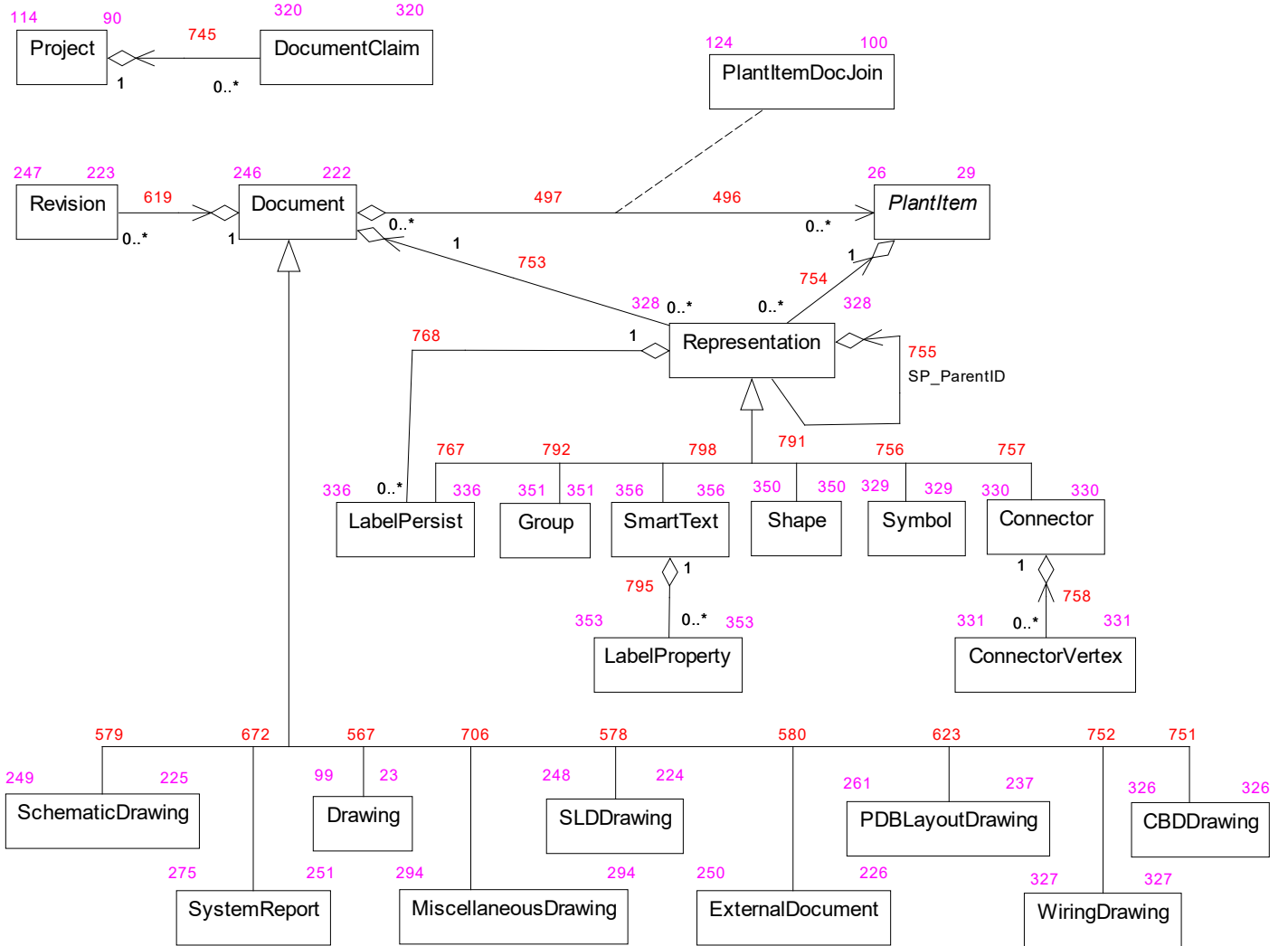

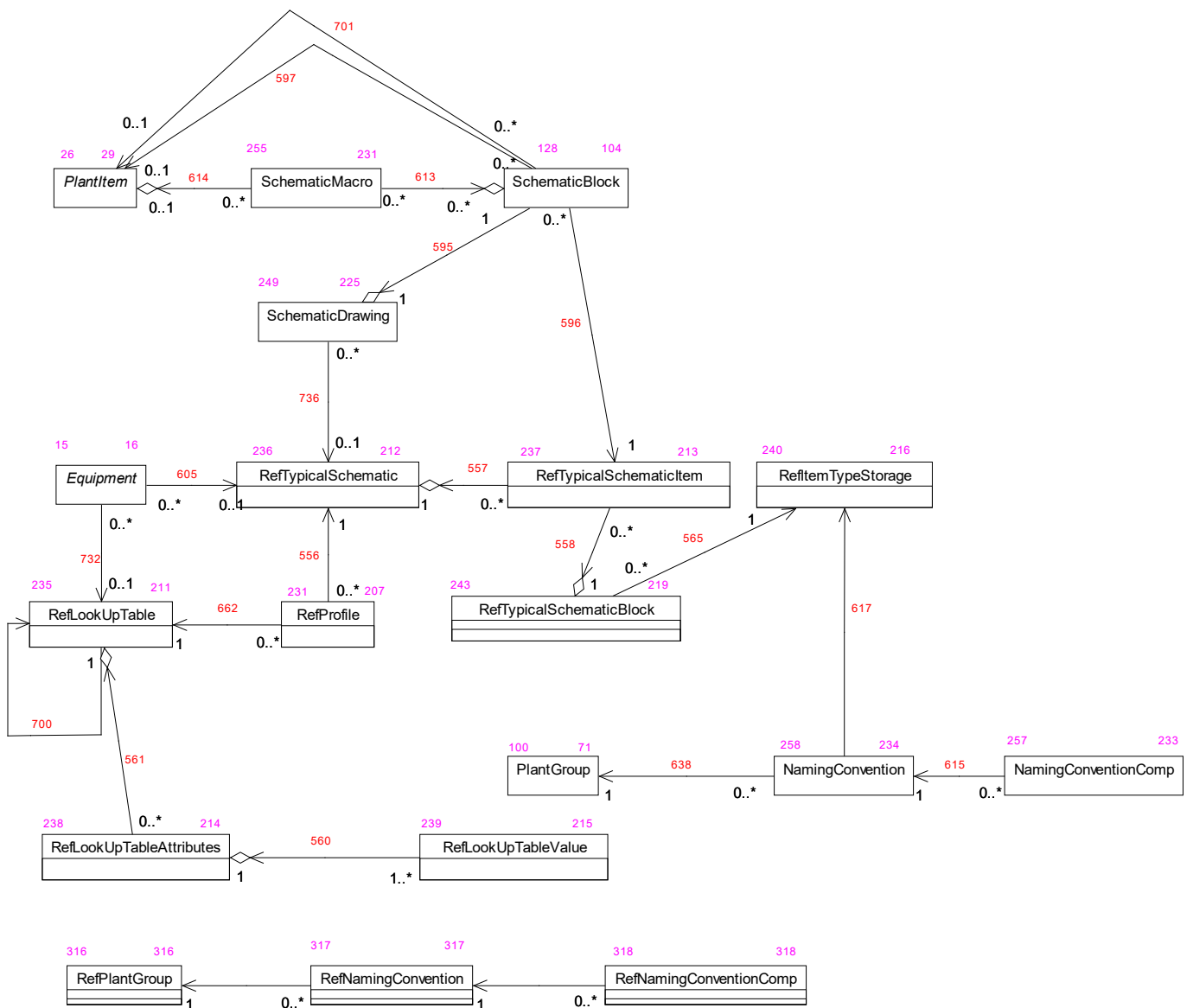

The RefTypicalSchematic and the SchematicDrawing (page 9) relate to Equipment and are also published to INtools.

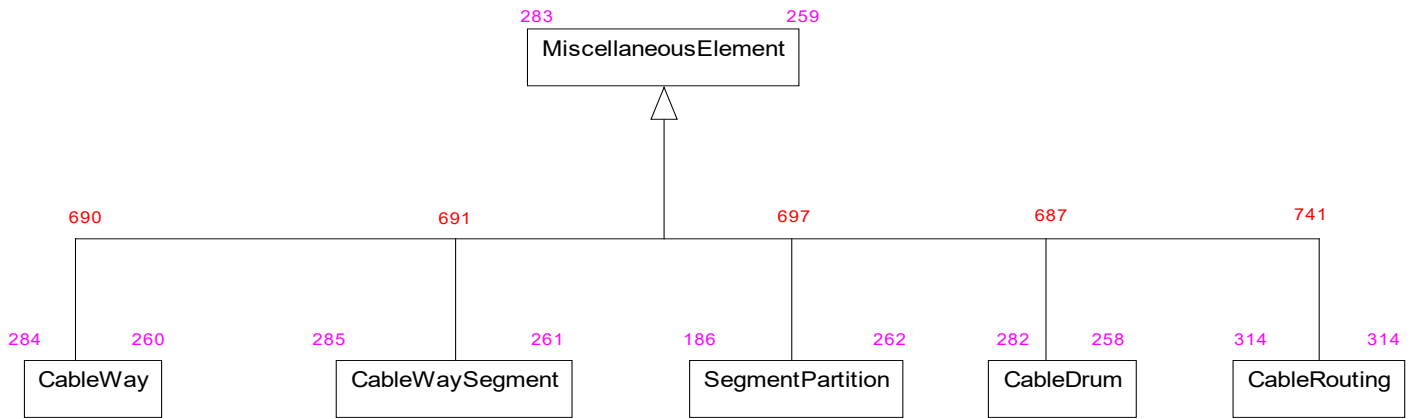

Configuration model

